

Extruded aluminum cardframe meets VME (IEEE1101.1) standards

This design, the first of its kind, provides a durable assembly that features an extruded panel of card guides. These card guides are spaced and sized according to the specific bus structure, such as VMEbus.

Very effective cooling can be accomplished with uninterrupted airflow through punched openings between the card guide slots.

Extremely efficient for conducting and removing heat from a crowded environment, this all-aluminum cage also eliminates the problem of flexing and breakage. Plastic card guides will bend over a short distance allowing misalignment.

The side plates are assembled to each rail with stainless steel 8-32 screws.

Not only robust but also durable, these card cages are also the first to feature an epoxy powder coating. This coating gives the card cage assembly a uniform textured finish. This finish is non-conductive and highly resistant to chipping, scratching and salt spray.

Patent 5,506, 751



Features:

- One piece extruded aluminum card guides.
- Punched openings between card guides.
- Durable card cage powder coated finish.
- Available Triple-Ease™ front panels with same card cage finish.

Benefits:

- Good heat transfer and not limited to 160mm depth.
- For effective cooling capability.
- Resists chipping, scratching and salt spray
- For uniform appearance, these also solve 14 major design problems; ask for brochure.

Triple-E Card Cages

- Meets industry standards for VME (IEEE1101.1)
- Can be fabricated to suit customer requirements
- Card Cage with backplane assembly is available – consult factory. We can also supply a fully wired powered enclosure, including power supply and cooling fans.

Ordering Information



Specifications:

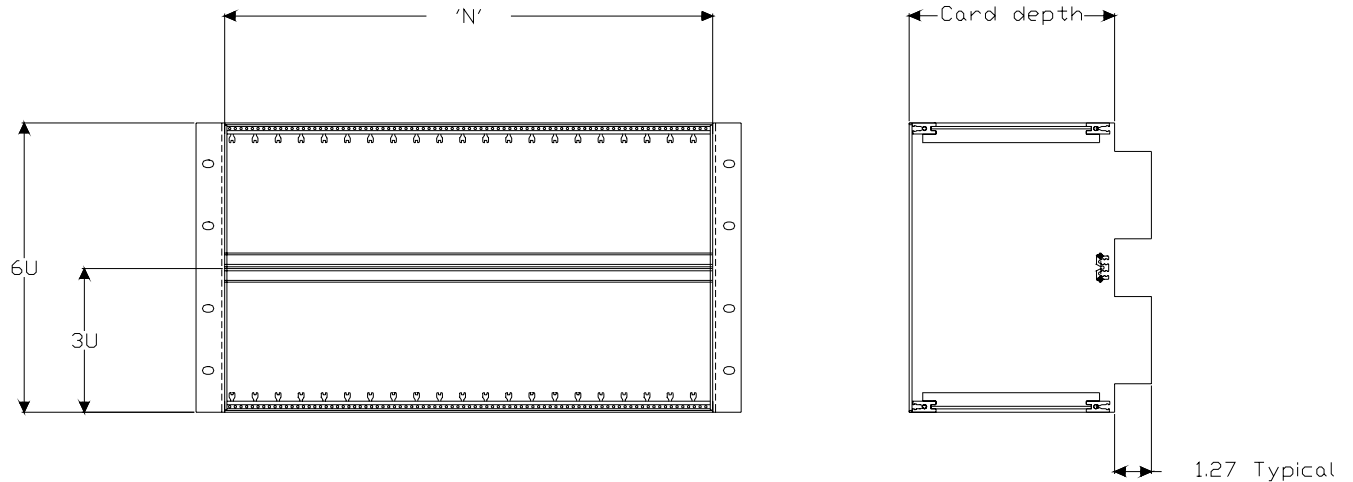

Ordering Information

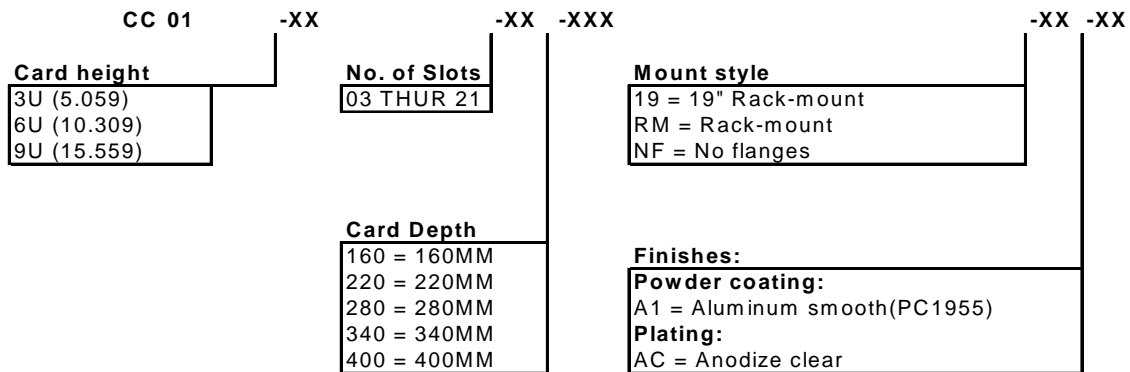

Example: 21 slot rack-mount card cage
6U x 160mm
Smooth aluminum powder coat

Our part number: CC01-6U-21-160-RM-A1

Notes:

** Card cage total width equals the number of slots (N) x 0.80" + 0.386"
 (Example a 21 slot card cage width (w) equals 21 x 0.80" + 0.386" = 17.186" overall)